

## Fully coated CTMP board with white coated reverse

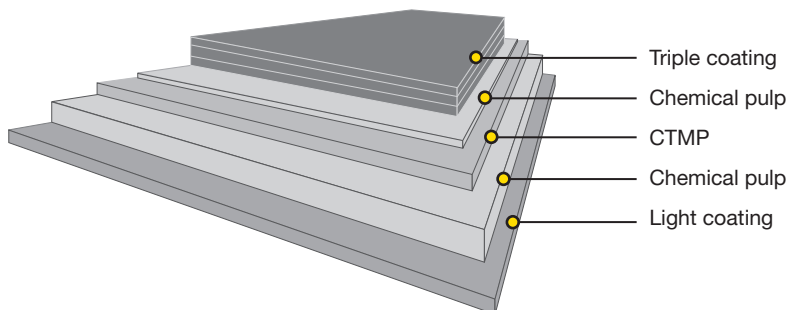

Issued: 07.2017  
Cancels: 08.2016

### Technical specification

Property / Unit	Tolerance											Standards
Grammage, g/m <sup>2</sup>	+3%/-5%	180	200	215	230	245	260	280	300	320	345	ISO 536
Thickness, µm	±5%	255	305	330	360	390	415	455	495	535	585	ISO 534
Bending moment Taber 15° MD, mNm	-15%	5.2	7.1	9.0	10.8	13.8	16.6	20.8	24.9	29.8	36.9	ISO 2493
Bending moment Taber 15° CD, mNm	-15%	2.6	3.5	4.4	5.3	6.8	8.1	10.1	12.1	14.6	18.1	
Bending resistance L&W 15° MD, mN	-15%	108	147	186	224	286	343	430	515	618	765	
Bending resistance L&W 15° CD, mN	-15%	53	72	91	110	140	167	210	250	303	375	
Moisture, %	±1	6.2	6.8	7.2	7.8	8.0	8.1	8.3	8.6	8.7	8.8	ISO 287
ISO Brightness C/2°, %, Top	min. 89	92	92	92	92	92	92	92	92	92	92	ISO 2470
ISO Brightness C/2°, %, Reverse	min. 87	90	90	90	90	90	90	90	90	90	90	
CIE Whiteness D65/10°, Top		122	122	122	122	122	122	122	122	122	122	ISO 11475
CIE Whiteness D65/10°, Reverse		120	120	120	120	120	120	120	120	120	120	
L*, Top		95.5	95.5	95.5	95.5	95.5	95.5	95.5	95.5	95.5	95.5	
a*, Top		1.9	1.9	1.9	1.9	1.9	1.9	1.9	1.9	1.9	1.9	
b*, Top		-7.5	-7.5	-7.5	-7.5	-7.5	-7.5	-7.5	-7.5	-7.5	-7.5	
Surface Smoothness, PPS 10, µm, Top	max. 1.5	1.0	1.0	1.0	1.0	1.0	1.0	1.0	1.0	1.0	1.0	ISO 8791-4
Surface Smoothness, PPS 10, µm, Reverse	max. 7.5	5.5	5.5	5.5	5.5	5.5	5.5	5.5	5.5	5.5	5.5	
Gloss 75°, %		45	45	45	45	45	45	45	45	45	45	ISO 8254-1
Scott Bond, J/m <sup>2</sup>	min. 110	145	145	145	145	145	145	145	145	145	145	TAPPI 569
Edge wicking*, g/mm.m	max. 1.0	0.5	0.5	0.5	0.5	0.5	0.5	0.5	0.5	0.5	0.5	
Cobb 60, g/m <sup>2</sup> , Top	max. 60	30	30	30	30	30	30	30	30	30	30	ISO 535
Cobb 60, g/m <sup>2</sup> , Reverse	max. 60	30	30	30	30	30	30	30	30	30	30	

\*) Hardsized available in all grammages

All properties according to Fors Mill measurements.

Test climate 23°C / 50 % RH (according to ISO 187).

Tolerances based upon 95 % confidence limits, apply to reel/pallet average. In order to verify, reel/pallet average shall be based on 5 single measurements randomly sampled within the reel/pallet. These averages will be for at least 19 of 20 reels/pallets within the specification limits.

#### Certificates

Quality management ISO 9001  
Environmental management ISO 14001  
Product safety ISO 22000  
Health and safety OHSAS 18001  
Energy management ISO 50001  
Forest certification and Chain-of-Custody, FSC® (logo licence number FSC-C105192), PEFC™ (logo licence number PEFC/02-31-71)

Paperboard is recyclable 